

G-G  
1:1

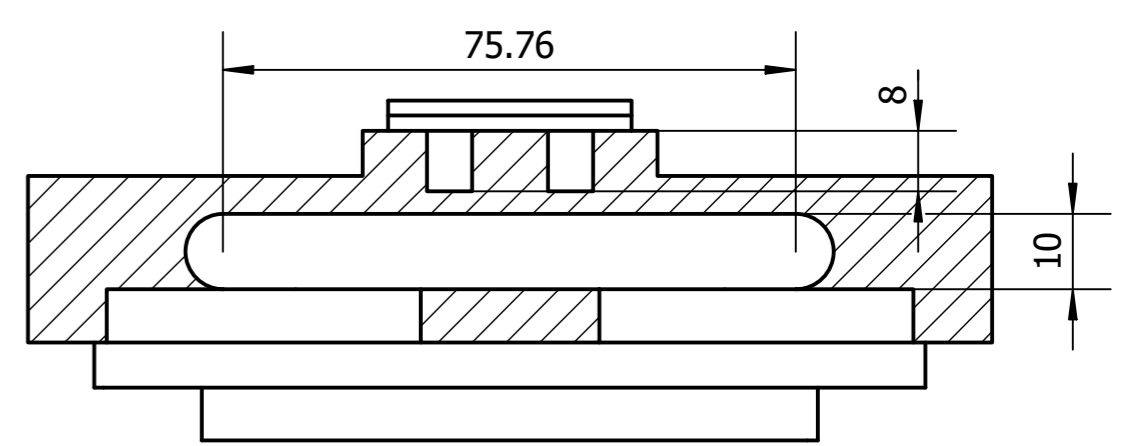

F-F  
1:1

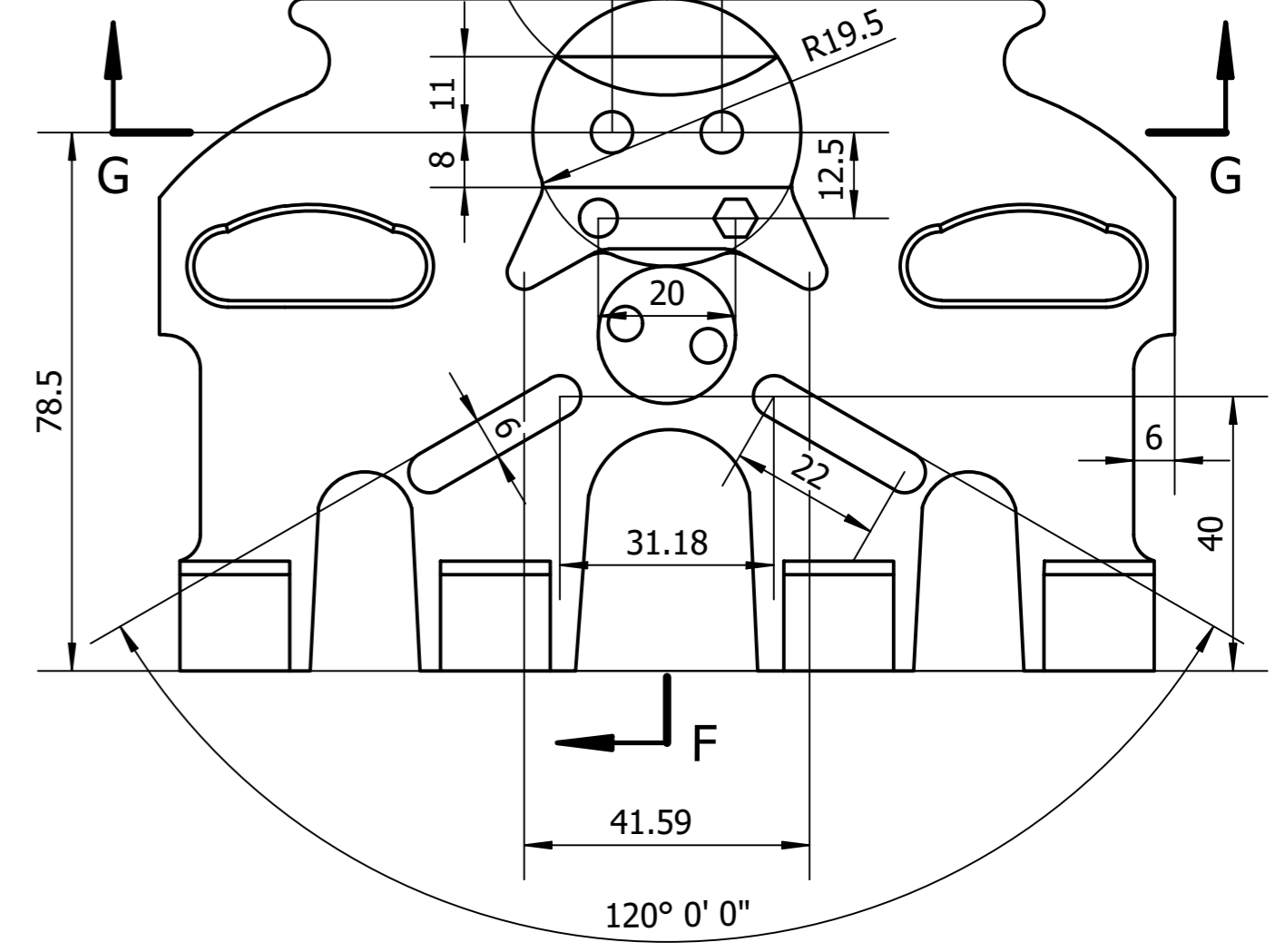
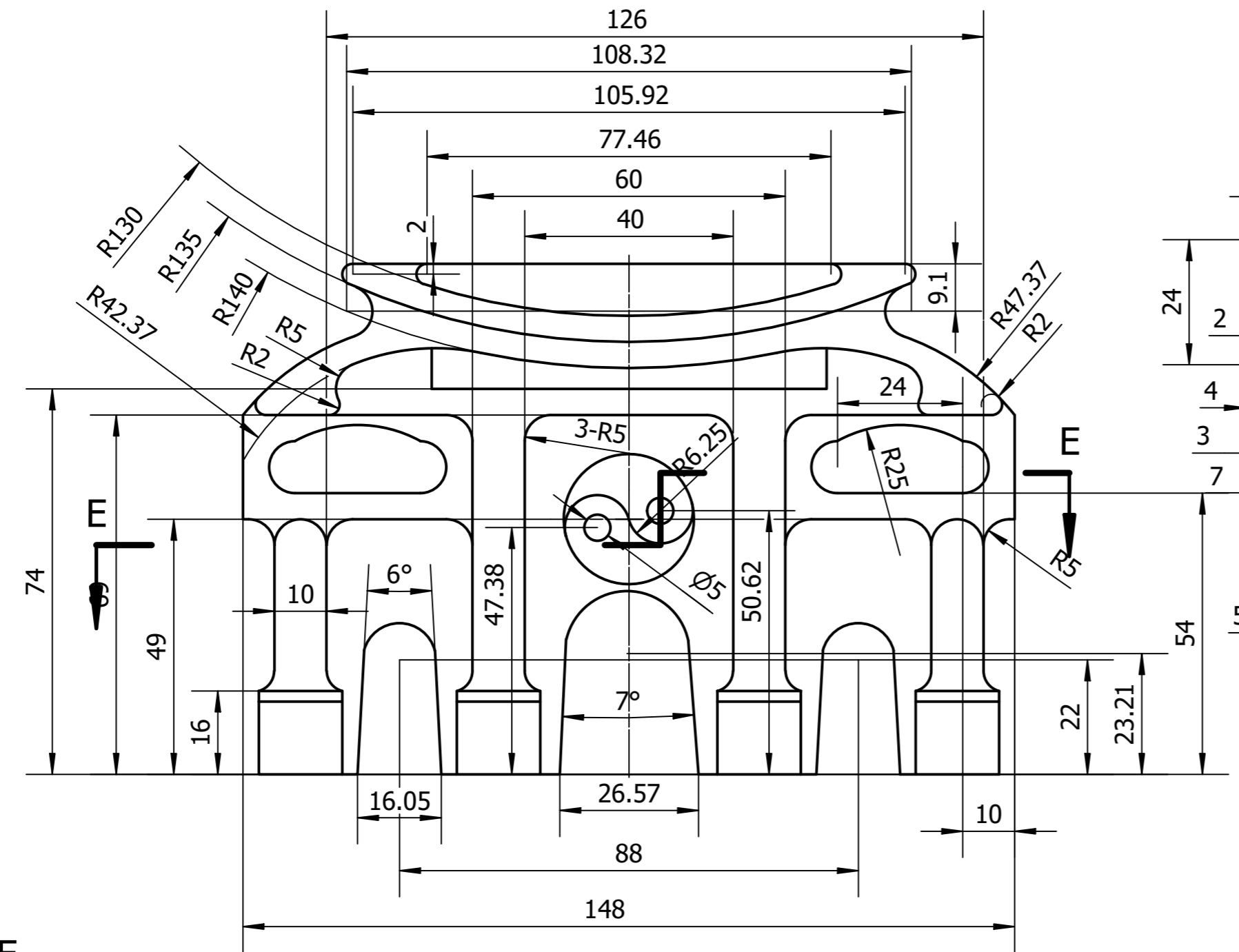
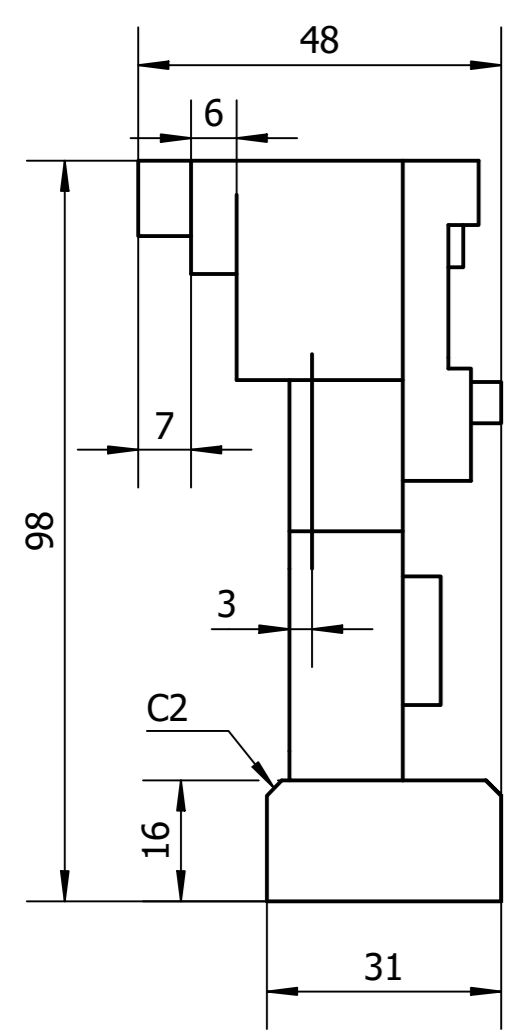
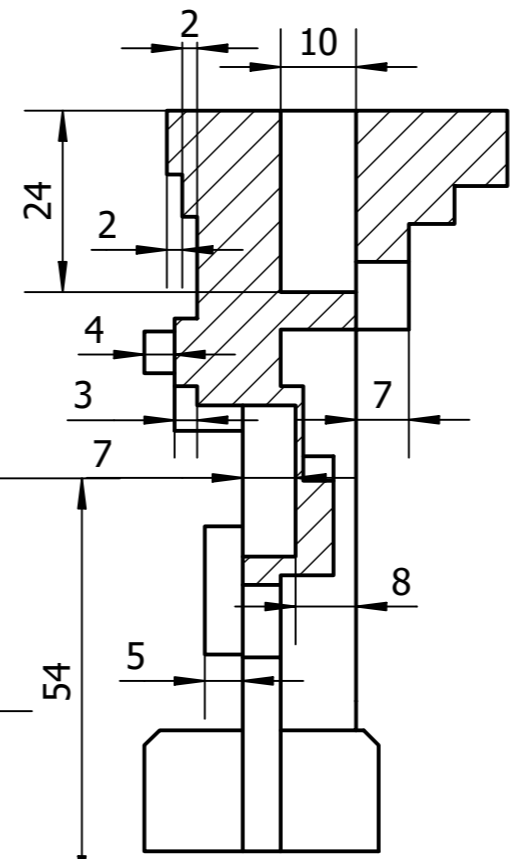

E-E  
1:1

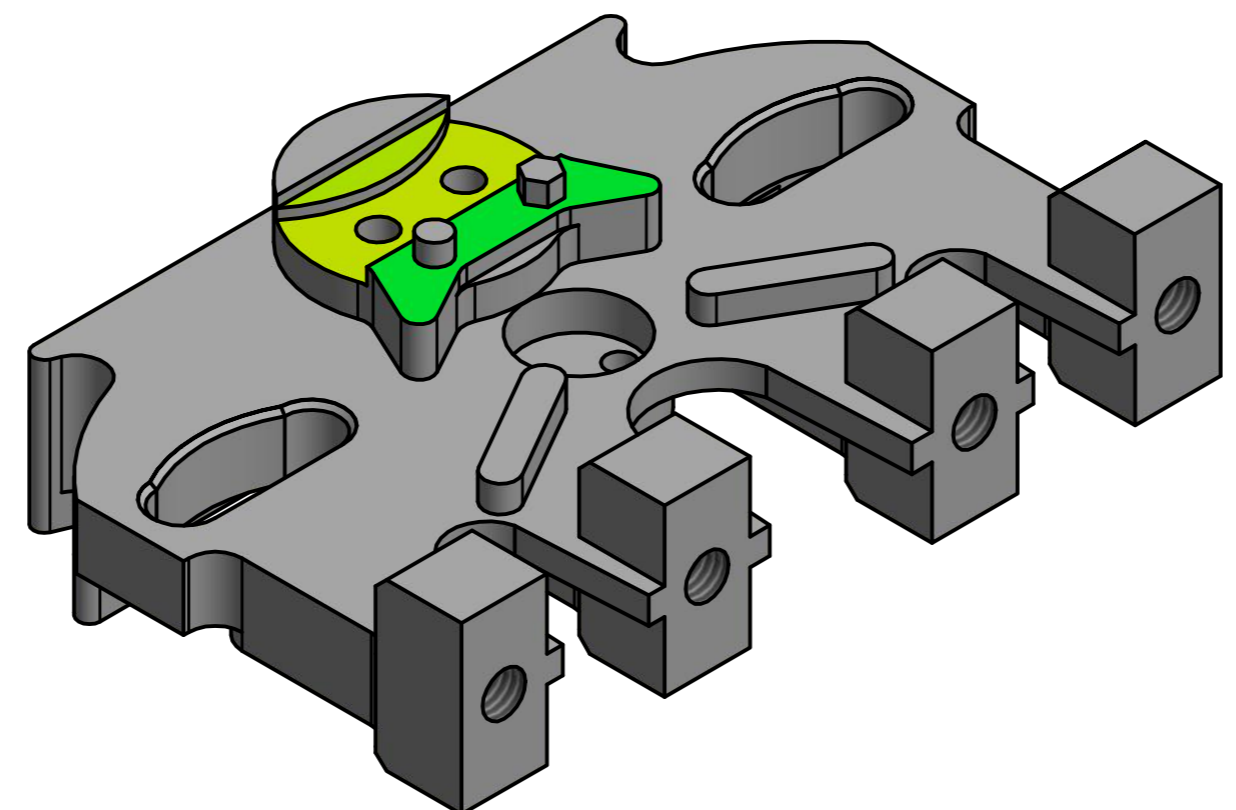
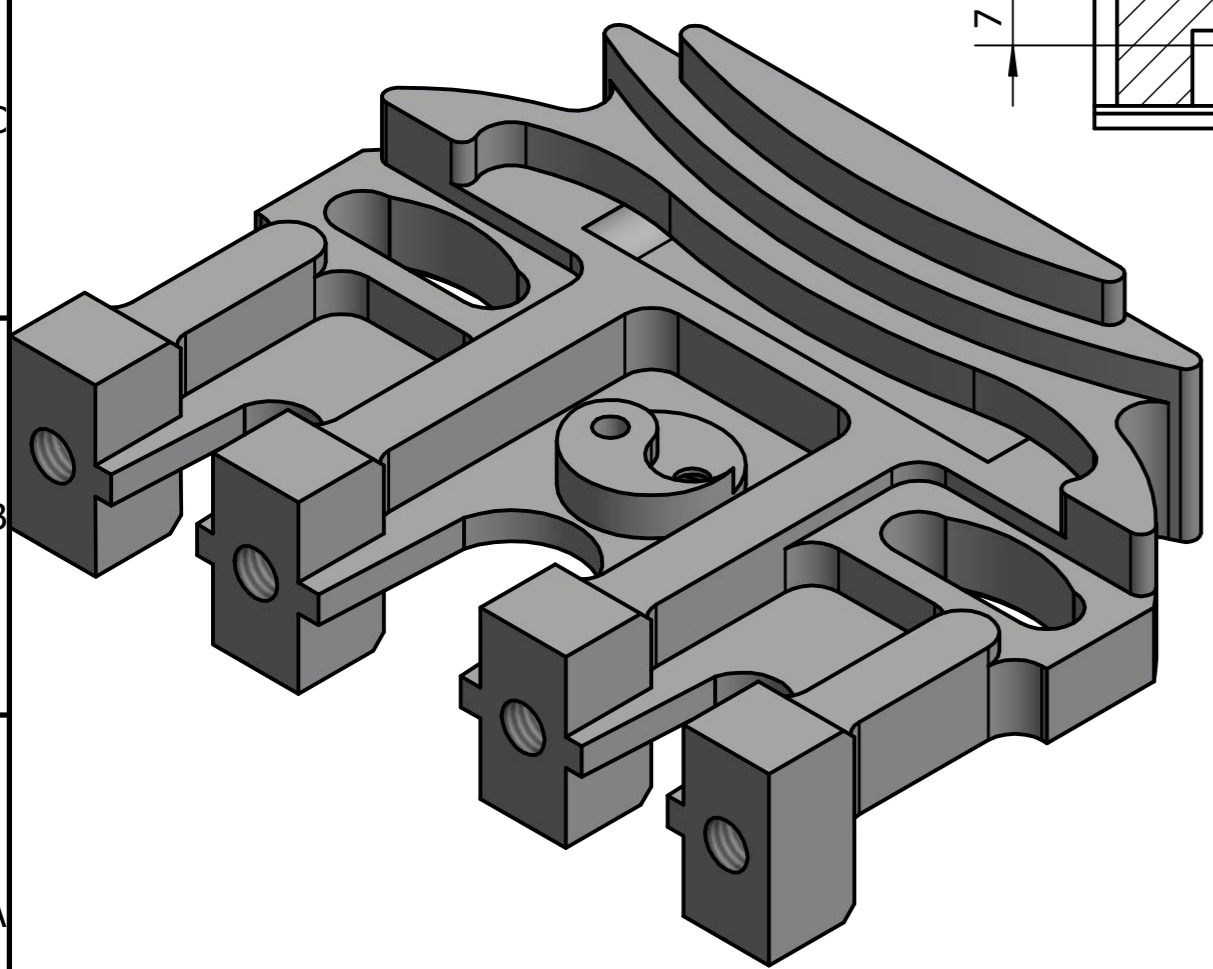
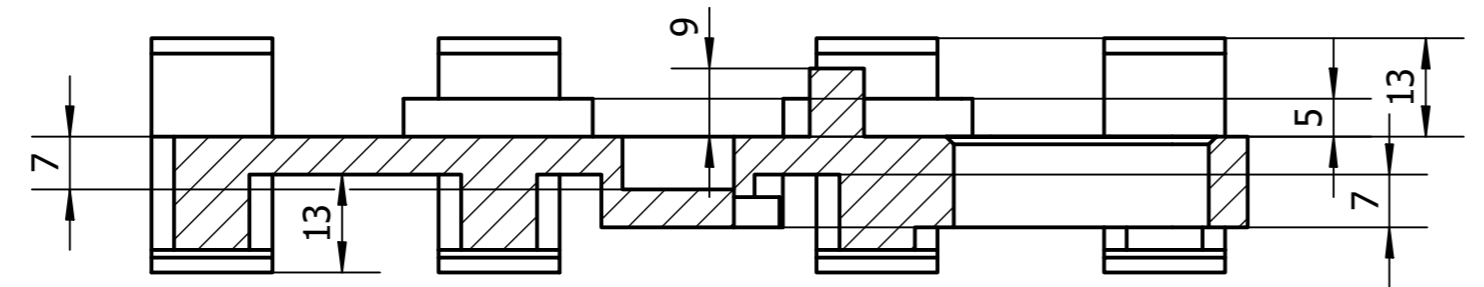

技术要求:

1. 未注倒角均为C0.2;
2. 未注圆角均为R0.5;
3. 未注公差均需符合GB/T1804-2000要求;
4. 零件需除去氧化皮, 加工后不能有毛刺、飞边;
5. 零件加工表面不能有划痕、刀伤等。

中华人民共和国第二届职业技能大赛甘肃省选拔赛

技能考核样卷

项 目	数 控 铣
图 号	SKX-M1
材 料	45钢
竞赛时长	240分钟